

## THE JOURNAL

OF THE

## American Chemical Society

---

**BORIC ACID: ITS DETECTION AND DETERMINATION IN  
LARGE OR SMALL AMOUNTS.**

By WILSON H. LOW.

Received April 18, 1906.

MANY good articles have been published on the detection and determination of boric acid, but they are rather fragmentary in character, and while helping in one direction, have left much to be desired in another. Most processes are tedious of execution and do not give evidence that all the boric acid will be obtained.

I have discovered two points in regard to the detection and determination of boric acid, which I believe are new.

One of these is that in the qualitative test it is not necessary to dry the turmeric paper at the temperature of the water-bath, but that the test carried on at the ordinary temperature in the air or vacuum desiccator, or even at 40-50° in a desiccator, is exceedingly delicate and allows the detection of boric acid in the presence of large amounts of other salts and in the presence of such interfering agents as nitrates and phosphates, when it would be entirely overlooked by the ordinary methods.

I do not know the limit of the qualitative test, but such small quantities of boric acid as 0.000001 gram in 1 cc. or 0.0000001 gram in 0.10 cc. are easily recognized, and these same quantities would undoubtedly be recognized by the evaporation of larger quantities of the solvent.

The other point applies to the quantitative determination. It is very difficult to distil off all the boric acid from an aqueous solution, by passing the vapor of methyl alcohol through it. As

long as any quantity of water remains it will retain boric acid, but it has been found that, by adding some substance to unite with the water, it is possible to distil off the total boric acid easily and with no tedious evaporation to dryness, with the attendant bumping and danger of breakage. Such a substance is the dry, granulated, chemically pure calcium chloride.

The methods described below have been in use about three years, and a great many experiments have been made to test the various points brought out. Further experiments will bring out other points of value, but the methods are in good shape and if followed as directed, will give the desired result. The methods will first be given as they are expected to be carried out, and further on will be given the experiments, or some of them, on which the processes stand. The action of indicators in the presence of boric acid and in the presence of methyl alcohol will also be given.

Wherever methyl alcohol is mentioned, the laboratory refined Columbian or Colonial spirits of commerce is meant. In the refined state, as it is purchased, it contains boric acid and this has to be removed and the alcohol tested to make sure it is entirely free from it.

#### QUALITATIVE TEST.

The test is given as applied to meat products, but obviously it may be applied to anything where the boric acid can be obtained in a soluble form. Ten grams of the hashed meat are placed in a metal dish (the cover of a three-pound lard pail is as good as anything, if well cleaned) and moistened with 5 cc. of a  $N/2$  solution of sodium carbonate or its equivalent. Place on the steam-bath or in an oven till about dry. Drying may be done nicely on a small electric stove. Ignite the dry mass, over a burner that heats the whole bottom of the dish evenly. Do not use a high heat. Thoroughly carbonize the ash, but do not bother to burn off much of it. Burning off is dangerous, as boron compounds may be volatilized when ignited in the presence of carbon. Direct experiments have shown this. The carbonized ash is placed in a mortar (a glass mortar is best) and ground up somewhat and then about 10 cc. of water containing 1 cc. of strong hydrochloric acid added and triturated with it. Filter off through a small filter (a small Witt's plate is best, as it retains very little

liquid) into a flat platinum or glass dish. A Petri dish 7-10 cm. in diameter is good.

About 1 cc. or less of the solution is taken and placed in a watch-glass and evaporated on the steam-bath with a piece of turmeric paper. If boric acid is present in the food product as a preservative, and there are no interfering agents, such as nitre, present, then a test for boric acid will be obtained here. This does not mean that if a test is obtained here the food product necessarily contained boric acid added for preserving purposes, but merely that the test is delicate enough to detect any possible amount of boric acid that would be added intentionally. The main lot of solution is placed in a shallow dish with a piece of turmeric paper, and then placed in a desiccator till *perfectly* dry. A vacuum drying oven is best, as the drying is rapid. I use a vacuum drying oven and can control the heat, using generally 40-50° and about 700 mm. vacuum. The smallest traces of boric acid will show up in this test. It is more delicate, if anything, if the drying is done in an ordinary desiccator, but the time of drying is very long. Tests that fail utterly on the steam-bath will show up strongly under these conditions. Nothing which I have tried, such as nitre, salt, sulphates or even phosphoric acid, has interfered with the test. Nitre will destroy the test carried on on the steam-bath and many other salts will seriously interfere. Make sure the turmeric paper is perfectly dry, for incrusting salts often give the appearance of dryness while the underlying paper is still moist. Food products should not be condemned because a strong test is obtained by operating in this manner. Added boric acid is easily detected by moistening the turmeric paper with the solution and drying on the steam-bath. If nitre is present, it can be gotten rid of (for the steam-bath test) by igniting with sufficient organic matter or, better, by distilling off the boric acid with methyl alcohol and testing the distillate. In testing qualitatively, the best result seems to be given with a solution containing at least one-tenth its volume of free strong hydrochloric acid, if the test is made on the steam-bath. For the test at ordinary temperature or at 40-50° a slight excess of acid is all that is needed, though greater excess does no harm. For the delicate test I should advise against the use of the trade mark glasses, as they are borosilicates and I have some indications that they will give up boric acid.

In the following tests the final volume before evaporation was 2 cc. unless otherwise stated. The turmeric paper was about  $50 \times 9$  mm. and the ordinary paper supplied by chemical dealers. A steam-bath was used with the first twenty tests.

The last test repeated on the steam-bath will bleach the paper owing to the formation of chlorine compounds.

Many other tests have been tried and nothing found to interfere with the test made by drying in the vacuum desiccator or oven.

There appears to be no loss of boric acid in concentrating a large volume of solution in the vacuum, and the test is just as strong as where only 1 cc. is used. 0.00001 gram of boric acid is equivalent to 0.0001 per cent. when 10 grams of material are operated on, and this quantity is infinitesimal for a preservative. As far as that is concerned, the simplest kind of a test, carried out in the roughest manner, is amply delicate to detect any boric acid added for preserving purposes. The exception to be noted is where there is a nitrate present.

#### QUANTITATIVE TEST.

*Reagents.*—Methyl alcohol free from boric acid; methyl orange indicator; *p*-nitrophenol indicator; phenolphthalein indicator; hydrochloric acid free from boric acid; calcium chloride, granulated, chemically pure; standard solution of sodium hydroxide, as free as possible from carbonate; standard solution of sulphuric acid, as free as possible from carbonate; whether these solutions are normal or of other strength depends on what quantity of boric acid is being dealt with. Both normal and tenth-normal are useful.

*Standard Solutions.*—The standard solutions of acid and alkali are made up in this laboratory from distilled water which has been distilled from a block-tin (solid) still and condenser and subsequently boiled hard for about twenty minutes in another block-tin vessel furnished with a connection to a large soda-lime column. After boiling, the vessel is furnished with a tin condensing pipe inside to cool the water rapidly. All air entering the vessel has to come through the soda-lime column, and the water keeps free from carbonic acid. While 100 cc. of the ordinary distilled water will take about 15 drops of *N*/10 sodium hydroxide solution to give a *permanent* coloration with phenolphthalein, the boiled water allows the permanent coloration to show up

Test.	Final volume of solution. cc.	Boric acid present. Gram.	Excess of strong HCl.	Other things present.	Indications.
1	2.00	0.0000000	2 drops	Nothing	None
2	2.00	0.0000010	2 drops	"	Merest trace
3	2.00	0.0000100	2 drops	"	Strong test
4	2.00	0.0000050	2 drops	"	Strong test
5	2.00	0.000025	2 drops	"	Slight test
6	2.00	none added	2 drops	1 cc. N/1 NaOH	None
7	2.00	0.0000025	2 drops	1 cc. N/1 NaOH	None
8	2.00	0.0000050	4 drops	1 cc. N/1 NaOH	Slight trace
9	2.00	0.0000100	4 drops	1 cc. N/1 NaOH	Mere trace

The above tests show the sensitiveness without interfering substances present and also how sodium chloride interferes, when present.

10	2.00	0.0000050	2 drops	5 cc. Ba(OH) <sub>2</sub>	No test
11	2.00	0.0000100	4 drops	1 cc. N/1 NaOH	Mere trace
12	2.00	0.0000100	2 drops	Salt from 1 cc. N/1 NaOH	Mere trace
13	2.00	0.0000150	2 drops	Nothing	Good test
14	2.00	none added	2 drops	Salt from 1 cc. N/1 NaOH	Trace
15	2.00	0.0000100	10 drops	Salt from 1 cc. N/1 NaOH	Slight trace
16	2.00	0.0000200	2 drops	Salt from 1 cc. N/1 NaOH	Slight trace
17	2.00	0.0000200	10 drops	Salt from 1 cc. N/1 NaOH	Slight test
18	2.00	0.0000250	2 drops	Salt from 1 cc. N/1 NaOH	Slight test
19	2.00	0.0000300	2 drops	Salt from 1 cc. N/1 NaOH	Plain test
20	2.00	0.0000100	2 drops	15 gms. of sand + 2 cc. of curcuma solution	Faint test

The following tests were made at the ordinary temperature or not to exceed 40° C. Either a vacuum drier or an ordinary desiccator was used. V=vacuum drier and D=desiccator.

21 V	2.00	0.0000100	2 drops	Salt from 1 cc. N/1 NaOH	Strong test
22 V	2.00	0.0000010	2 drops	Salt from 1 cc. N/1 NaOH	Plain test
23 D	1.00	0.0000010	1 drop	Nothing	Strong test
24 D	0.10	0.0000001	½ drop	Nothing	Plain test
25 V	10.00	0.0000100	1 drop	1 cc. saturated sol. Na <sub>2</sub> CO <sub>3</sub>	Strong test
26 V	10.00	0.0000100	1 drop	1 drop of syrupy phosphoric acid	Strong test
27 V	10.00	0.0000100	1 drop	1 cc. potassium nitrate solution	Strong test

strongly with one drop, and this is almost sufficient for a litre of the boiled water. Incidentally, I will remark that sodium thiosulphate solutions made up with this water will keep their correct strength almost indefinitely and deposit no sulphur.

*Preparation of the Methyl Alcohol.*—"Columbian" or "Colonial Spirits" are introduced into a still of some kind and made *strongly* alkaline with some very concentrated caustic soda or potash. If a glass vessel is used, it must be furnished with a capillary boiling tube, and the size of this tube adapted to the size of the flask, etc.<sup>1</sup> Distil off the alcohol carefully and run a blank through the apparatus (putting alkali in the boiling flask) and see if there is any titratable amount of boric acid given off. If not, the alcohol is all right. Where the alcohol is to be used to collect the boric acid for a subsequent qualitative test, it must be purified till 100 cc. of distillate give no test for boric acid qualitatively.

*Effect of Methyl Alcohol on p-Nitrophenol and on Phenolphthalein.*—The alcohol recently distilled from an excess of alkali is meant in all cases. 100 cc. of the alcohol were taken and one drop of the nitrophenol indicator added. The color was yellow. N/10 sulphuric acid was run in till the solution was colorless. 0.90 cc. was used. One drop of N/1 sodium hydroxide brought back the yellow very strong. Experiment repeated except N/1 sulphuric acid was used. Result the same, two drops = 0.10 cc. being used. This relationship between one drop of nitrophenol and methyl alcohol holds roughly for various dilutions and a delicate method of testing for acidity in methyl alcohol might be arranged from this fact. In our case all we wanted was to make sure that we could titrate the mineral acid in the methyl alcohol distillate fairly close, and this is demonstrated.

Phenolphthalein is of little use in titrating acidity in methyl alcohol. Great dilution is necessary before the indications are good. But after the alcohol is made neutral or slightly alkaline (after previously being acid) to nitrophenol then phenolphthalein may be depended on to indicate pretty closely the end-point for a boric acid titration.

*Indicators.*—Phenolphthalein is made up by dissolving 5 grams in 500 cc. of ethyl alcohol and making up to 1 liter. Use about 1 cc. in tests.

<sup>1</sup> See Heyward Scudder : This Journal, 25, 163.

*p*-Nitrophenol.—This indicator was ordered as nitrosophenol and came marked as nitrosophenol, but as it fails to give Liebermann's reaction for nitroso compounds and has a melting-point of about 113° it must be simply *p*-nitrophenol and not the nitroso-compound.

Make up by dissolving 1 gram in 75 cc. of neutral ethyl alcohol and add 25 cc. of water. Use 1 drop to 100 cc. of the solution to be titrated. As this indicator is, perhaps, not well-known I will give its properties as I have found them. My attention was first called to this indicator by an article by L. Spiegel in the *J. Chem. Ind.* **19**, 1049 (1900). He recommends it to replace methyl orange. I can corroborate his statements and also those he makes in the same journal **23**, 682, where he takes issue with Lunge on its being able to replace methyl orange for many titrations. This indicator is about as sensitive as phenolphthalein. Colorless with mineral acids and intensely yellow with caustic or carbonated alkalis. With bicarbonates the yellow shade is much weaker, but still bicarbonates can be titrated, if care is used. In boric acid titrations, avoid carbonates as much as possible. If 100 cc. of water is made just alkaline to nitrophenol, on adding glycerol the solution becomes colorless when boric acid is present, though boric acid gives no indication in aqueous solution, unless it is a strong solution, in which case even methyl orange will react acid. No distinct end-point can be obtained with nitrophenol in the presence of glycerol and boric acid. As the boric acid comes nearer to  $\text{NaBO}_2$  the color of the solution becomes more intensely yellow, and this acts as a guide to the phenolphthalein end-point.

*Methyl Orange*.—One gram dissolved to 1 liter in water. It may be used in place of nitrophenol in aqueous solution, but not in methyl alcohol. It has the advantage over nitrophenol of being less sensitive to carbonic acid (though it is by no means entirely indifferent to this acid) and also less sensitive to boric acid in a strong aqueous solution. Its disadvantages are that it is not nearly as sensitive as nitrophenol and the end-reactions run through several shades of color, and it cannot be used in methyl alcohol with any accuracy. I seldom use it for boric acid titrations.

We have found that methyl orange and nitrophenol give the same end-points in titrating sodium hydroxide or ammonia.

Remember always that the color is much weaker in the presence of bicarbonates.

In the absence of interfering agents and complete absence of carbonic acid, phenolphthalein, methyl orange and nitrophenol in aqueous solution will give identical end-points.

#### QUANTITATIVE TEST.

The limit of the test, as here arranged, is 1 drop or 0.05 cc. of N/10 sodium hydroxide solution. This corresponds to 0.00031 gram of boric acid or 0.00062 per cent. or about 0.10 ounce per 100 pounds of the food product, a quantity absurdly small for any preservative effect.

The sample of meat or other food product is ground up or hashed and 50 grams of the well-mixed sample taken and placed in a clean cover of a three-pound lard pail, or other similar dish. Spread the meat in a layer over the dish and moisten with 25 cc. of N/1 sodium carbonate solution or equivalent, and dry on the steam-bath, oven or electric stove. It is a great advantage to dry before igniting, as by so doing the meat does not swell up, and burns off much easier. The quantity of sodium carbonate directed to be added is more than sufficient to retain 1 per cent. of boric acid, and this is more than would be used. 25 cc. of N/2 sodium carbonate are generally sufficient and makes the burning to carbonaceous ash quicker. Ignite gently, heating the whole bottom of the dish, if possible, to a carbonaceous ash free from brown products soluble in water. Do not burn off all the carbon. Allow to cool and with a spatula scrape out the ash into a smooth mortar (a glass mortar is best). Grind up fairly fine and transfer from the mortar to the distillation flask. This is easily done as the smooth mortar allows the ash to slide out completely. Put about 10 cc. of water into the dish from which the ash was scraped, add 1 cc. of strong hydrochloric acid and allow to act about thirty seconds (we want to avoid dissolving the iron to any extent) and then pour into the distillation flask. This will sufficiently wash out the dish, and there would be no particular loss if this step was left out. About 3 to 5 cc. of strong hydrochloric acid are added to the distillation flask and the ash allowed to soak in the liquid for a few minutes to dissolve as much as possible, the object being to get all the boric acid in solution. Ten to 15 grams of dry, granulated, chemically pure calcium chloride are now added and allowed to dissolve as much as will in a few minutes



shaking. Connect up the flask in its place in the distillation system and pass methyl alcohol vapor through. Usually no attempt is made to heat this flask except by the methyl alcohol vapor itself, but there is no harm in so doing after 50 to 100 cc. of the alcohol have condensed in it. When about 100 cc. of distillate has been obtained, it is drawn off and tested. The distillation is allowed to go on without interruption and each 100 cc. or less are drawn off and tested till no more boric acid is found. When the last distillate gives a test requiring only 1 drop of N/10 sodium hydroxide solution the process is generally assumed finished, as without great care the blank test on the glycerol alone or in the presence of salts will vary a drop. If necessary, the determination can be made absolutely to within 1 drop of N/10 sodium hydroxide.

Each distillate is tested as follows: It is drawn off into a flask similar to the distillation flask (a round-bottomed flask holding up to the neck about 275 cc.) and 1 drop of nitrophenol indicator solution added. N/1 sodium hydroxide solution is dropped in till the yellow color of the indicator is seen. Practically all the mineral acid that has distilled over is now neutralized. Experiment shows that very little mineral acid does distil over, even with a large excess in the distillation flask, unless the contents of the distillation flask are concentrated. Now add about 1 cc. of the phenolphthalein indicator and run in N/1 sodium hydroxide solution till the pink color is seen. As soon as you are sure the coloration is reddish or pink, that will do without making it strong. The difference between the end-points with nitrophenol and phenolphthalein will be a close measure of the boric acid present, as the methyl alcohol takes the part of glycerol and would probably be just as good as the latter but for its peculiar effect on some indicators. After finding how many cubic centimeters correspond to the boric acid, add twice as much more alkali; that is, if the difference in end-points between nitrophenol and phenolphthalein was 10 cc. then add 20 cc. more of the alkali. This is to insure enough alkali to combine with the boric acid to form  $\text{Na}_3\text{BO}_3$ , which is certainly enough to prevent loss of boric acid on evaporating off the methyl alcohol. In all probability, this is more than enough. The compound or mixture of boric acid and alkali that is stable in boiling methyl alcohol is stated by E. Polenske<sup>1</sup> to have the composition  $5\text{Na}_2\text{O} \cdot 4\text{B}_2\text{O}_3$  and this is

<sup>1</sup> J. Chem. Ind., 20, 273 (1901).

apparently a mixture of  $\text{NaBO}_2$  and  $\text{Na}_2\text{O}$ . Now put a capillary boiling tube into the flask and evaporate off the methyl alcohol on the steam-bath. When the alcohol has evaporated, dissolve the residue in about 25 cc. of water, and run in N/1 sulphuric acid till the solution is colorless. If a large quantity of N/1 sodium hydroxide solution has been used, necessitating a large quantity of acid, it is better to drop in strong hydrochloric acid till the solution is colorless, thus keeping the bulk down. Next, holding the neck of the flask with a clamp, put the flask into the steam-bath for a few minutes, take out and quickly connect with the suction pump (a large-sized Chapman is very good). The flask will be rapidly exhausted and the solution will boil vigorously and all carbon dioxide will be expelled. The evaporation cools the contents of the flask rapidly and, if there is any doubt that all carbon dioxide has been expelled, the heating and boiling may be repeated, as there is no fear of losing boric acid, except mechanically. Note that the solution should be colorless when hot as well as when cold; if not, add more acid and heat again. Sometimes the yellow color of the nitrophenol is seen in the hot liquid, due to the decomposition of the bicarbonates and showing that not enough acid has been added. The phenolphthalein indicator will often separate out as an insoluble white precipitate as the solution cools. This is of no particular consequence as it clears up again later, and experiments seem to indicate that 1 cc. of this indicator solution is better to use than a smaller quantity. The solution is now cold and free from carbon dioxide. Break the vacuum and run in N/1 sodium hydroxide solution till the last drop turns the nitrophenol indicator yellow. Now run back to acid reaction with 1 drop of N/1 sulphuric acid, and then run to just alkaline reaction with N/10 sodium hydroxide. In some cases in running to alkaline reaction with N/10 sodium hydroxide solution, the yellow color is very faint (due to large amounts of salts present or possibly to carbon dioxide not previously expelled), but usually it is well marked. At any rate run to the first point that you are sure is yellowish. Now take 40 cc. of strong glycerol in the 50 cc. graduated cylinder and pour it into the flask, rotating the latter to mix the contents. About 35 cc. of glycerol will flow out with moderate draining. The titration with N/10 or N/1 sodium hydroxide solution (depending on how large a quantity of boric acid is present, and the titration in methyl

alcohol has indicated this) is proceeded with till the last drop gives a decided color change to a reddish or pinkish shade. It is not necessary to run to a decided pink color as one drop of N/10 sodium hydroxide solution in excess makes a decided change from the strong yellow of the nitrophenol to a color with a reddish tint due to phenolphthalein. The progress of the titration is well seen in the change of depth of color due to nitrophenol. As the end-point is approached, the yellow color grows very intense. The difference between the end-point to nitrophenol and phenolphthalein multiplied by 0.0062024 gives the grams of boric acid, if N/10 alkali has been used in the titration. Each 100 cc. of distillate, or whatever quantity is drawn off each time, is tested in this way. A blank had best be run by taking 10 cc. of N/1 sodium hydroxide solution, adding a slight excess of N/1 sulphuric acid and about 10 cc. of water and boiling under vacuum as in the test, and then bringing to just alkaline reaction to nitrophenol with N/10 sodium hydroxide solution, adding the same amount of glycerol and titrating to the end-point with phenolphthalein indicator.

There need be no mistaking the end-points, and test experiments have shown that nitrophenol gives the same end-point as methyl orange (first noticeable change), and is greatly to be preferred, as there is no change through several shades to the end, as there is with methyl orange. However, methyl orange may be used with equal accuracy, paying due attention to running to the same shade of end-point each time. An exception must be made to the last statement in regard to the preliminary titration of the boric acid when in methyl alcohol solution. Methyl orange here is of no value. If for any reason it is found necessary to use more than 10 cc. of water and 5 cc. of hydrochloric acid in the distillation flask, it will be necessary to increase the amount of calcium chloride to take care of the additional water. Use about two-thirds of a gram of calcium chloride to 1 cc. of the aqueous solution in the distillation flask. The idea is to have all the boric acid in solution as then it is quickly volatilized. The arrangement of the apparatus will be seen from the sketch.

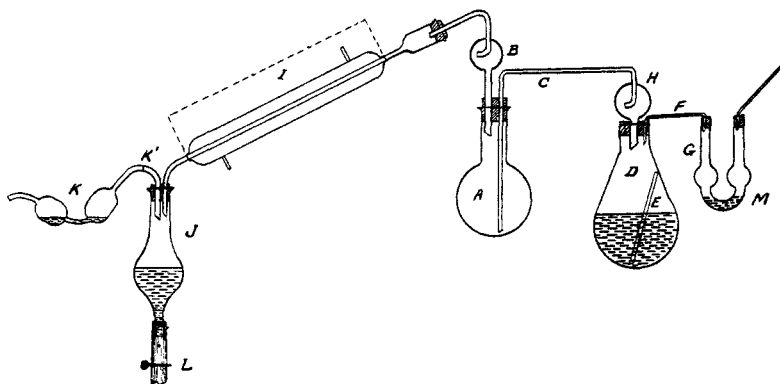

Fig. 1

- A, distillation flask. Capacity about 275 cc. Rests in asbestos cloth on retort stand ring.
- B, splash trap, about 5 cm. in diameter. From top of flask to top of bend is about 12 cm.
- C, vapor tube. Internal diameter about 4 mm. and at end inside the flask  $2\frac{1}{2}$  mm. this tube must not have too small an opening in the flask on account of danger of becoming clogged.
- D, flask made from an 800 cc. Jena glass Kjeldahl digestion flask, cut off as shown. The methyl alcohol is boiled in this flask. It is furnished with the absolutely necessary boiling tube E.
- E, boiling tube about 16 cm. long with a capillary bore. About 1 cm. from the end in the alcohol it is sealed. Without this tube the alcohol on boiling bumps fearfully and would endanger the apparatus and operator. With this tube the boiling is easy, uniform and without danger. It is necessary to shake out the alcohol from the capillary and put it back into the alcohol, each time the solution is started boiling.
- F, bend and rubber tube connecting the boiling flask with the small safety U-tube.
- G, U-tube of small size containing a little mercury in the bend. This acts as a safety-valve in case the apparatus gets clogged, and prevents the blowing out of the stopper from the boiling flask. A long tube leads from the U-tube to carry off the alcohol vapor should it blow out. The rubber tube should slope towards the boiling flask.
- H is a splash trap the same as B, except that the tube leads from it at right angles. It is connected with C, by a sliding piece of rubber tubing.
- I is the condenser about 38 cm. long between the dotted lines and about 50 cm. over all.
- J is the collecting flask. Mine is made by blowing out the bottom of a 200 cc. Erlenmeyer flask and drawing down to a tube. It is furnished with a rubber tube and pinch-cock at the bottom.

K is the absorption tube with the water seal, to prevent loss of methyl borate. At the end of each 100 cc. of distillate, the contents of this tube are run into the distillate taken off. K' = rubber connection.

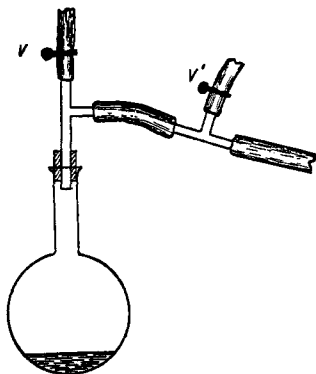

Fig. 2.

Flask connected to vacuum pump VV' are T tubes and rubber tubing with screw pinch-cocks. The vacuum should always be broken by opening cock V, to prevent any possible return of condensed water.

The following results are from an actual test: Fifty grams of meat taken + 25 cc. N/2 sodium carbonate solution.

First distillate, about 100 cc. After making alkaline to nitrophenol, took about 5.90 cc. N/1 sodium hydroxide to phenolphthalein end-point. Enough to make in all 17.7 cc. of the N/1 sodium hydroxide were added. After evaporating off the alcohol and getting the residue in proper solution, the titration for boric acid took 4 cc. of N/1 sodium hydroxide + 21.7 cc. N/10 sodium hydroxide, equivalent to 61.70 cc. N/10 solution in all. Deduct 0.25 cc. for the glycerol blank leaves 61.45 cc. as due to the boric acid in the first 100 cc. of distillate.

The boiling and distillation flasks are set on asbestos cloth and held in retort rings and clamps.

The apparatus works perfectly and I cannot say too much about the absolute necessity of the boiling tube at every stage where methyl alcohol is boiled in glass. In a metal dish it will boil without bumping, but not in glass. The boiling flask has some phenolphthalein added to it and enough concentrated sodium hydroxide (practically carbonate-free) to keep it permanently red. This insures no boric acid in the vapor.

All stoppers are of cork.

Second distillate, about 100 cc., took 6 cc. N/10 sodium hydroxide for the boric acid. This minus 0.25 for the glycerol blank leaves 5.75 cc. for the boric acid. The preliminary titration in methyl alcohol solution had indicated about 5.50 cc.

Third distillate, about 100 cc., took 0.57 cc. N/10 sodium hydroxide and this minus 0.25 cc. for the glycerol blank leaves 0.32 cc. for the boric acid.

Fourth distillate, about 50 cc., took 0.25 cc. N/10 sodium hydroxide, and this is the quantity taken by the glycerol alone, so all the boric acid has been obtained.

Total N/10 sodium hydroxide used for boric acid = 67.52 cc. and this multiplied by 0.0062 = 0.4168 gram = 0.837 per cent. on the meat taken.

This is a large quantity to be present under the circumstances and was more than I expected. Had it not been for the preliminary titration in methyl alcohol solution, enough alkali to retain the boric acid might not have been added and loss would have occurred while evaporating off the methyl alcohol. Had more calcium chloride been added at the start the first two distillates would probably have contained all the boric acid.

*Action of Boric Acid on Some Indicators.*—In all the following experiments, unless otherwise stated, the water used was free from carbon dioxide.

A solution of more than 2 grams of boric acid in 100 cc. will react acid to methyl orange and also to nitrophenol, more so to the latter than the former. Direct experiments have shown, however, that nitrophenol gives perfectly accurate results in boric acid titration, if carried out as directed. It is a great advantage to expel all carbon dioxide, and this applies to methyl orange as well.

*Loss of Boric Acid on Ignition with Organic Matter.*—On igniting boric acid and meat, strongly, to burn off as much carbon as possible, greenish flames were seen and the ash when tested gave a very slight qualitative test for boric acid, while there had been enough originally present to give a strong test.

Numerous experiments have been made to test the process at every essential point. Instead of giving the experiments in detail it will, perhaps, be sufficient to give in direct statements the results.

(1) A solution containing a small amount of boric acid may be concentrated from 100 cc. to 10 cc. without fear of a titratable amount of boric acid being lost.

(2) Boiling a dilute solution of boric acid to free it from carbon dioxide occasions no loss, unless the boiling is prolonged.

(3) All carbon dioxide is expelled from distilled water by heating to boiling and then applying vacuum for a few minutes till the solution is almost cold.

(4) Starting with a mixture in the distillation flask of 25 cc. of water and 25 cc. of methyl alcohol and passing methyl alcohol vapor through the mixture, while keeping the latter approximately at the same volume, it took fifty-five minutes and over 400 cc. of distillate before the temperature of the vapor leaving the distillation flask was anywhere near the boiling-point of methyl alcohol, showing the difficulty of driving off the water.

(5) Ten cc. of boric acid solution containing 0.3125 gram and 40 cc. methyl alcohol were distilled with methyl alcohol vapor. Seven successive distillates failed to get over all the boric acid.

(6) Where a water trap was not used the boric acid recovered was, in a certain case, equivalent to 4.90 cc. N/1 sodium hydroxide. Where a water trap was used 5.05 cc. N/1 sodium hydroxide were required. Theory called for 5.04 cc.

(7) By distilling a mixture of 1 volume of aqueous solution of boric acid with 10 volumes of methyl alcohol, till only 3 cc. of the mixture were left, about four-fifths of the boric acid were found in the distillate and one-fifth left in the flask.

(8) It was found that if calcium chloride was added to the distillation flask in the proportion of about 0.5 gram for each cubic centimeter of solution, all the boric acid came over quickly and completely. Using two-thirds of a gram of calcium chloride is better yet, unless some conditions make it impracticable to use this amount.

#### NOTES.

Make sure the methyl alcohol and calcium chloride used give no distillate containing a titratable quantity of boric acid. This may be insured by placing the calcium chloride in a separate flask, connecting with the distillation apparatus, acidifying with several drops of hydrochloric acid and passing methyl alcohol vapor through till the distillate gives no titration for boric acid.

This solution of calcium chloride is then added to the test instead of the solid salt. Nickel dishes or deep crucibles are very good for evaporating off alkaline solutions of methyl alcohol, containing boric acid. No boiling tube is required. While our method of freeing the solution from carbon dioxide, by boiling under a vacuum after heating on the steam-bath, appears all that could be desired, it is not suitable for freeing a solution of calcium bicarbonate from excess of carbon dioxide. Actual boiling under atmospheric pressure is required in this case as direct experiments have shown.

Sometimes iron appears to distil over with the methyl alcohol, when the contents of the distillation flask are strongly acid. This causes the end-point with nitrophenol to be somewhat obscure, as the solution will take on a reddish tinge before the strong yellow due to excess of alkali. It makes the solution look as if the phenolphthalein end-point was about to be reached, before the nitrophenol end-point had been seen. This has only occurred a few times and did little harm. This was noticed so recently, that I have not proved it to be caused by iron, but it appears to be iron.

In conclusion, I would like to draw attention to the very wide distribution of boric acid. It occurs in almost everything we meet in the food line, and caution should be used in reporting food as containing boric acid as a preservative without a quantitative determination. Ten grams of food product are quickly burned to ash and 50 to 100 cc. of methyl alcohol distilled from this ash will contain most of the boric acid, or even all, unless it is present in some quantity. Now 1 drop of N/10 sodium hydroxide on this quantity will equal 0.0031 per cent. of boric acid, much too small a quantity to have been added for preserving purposes, and yet large enough to have given a strong qualitative test.

Boric acid occurs naturally in apples and probably in other fruits and vegetables. It is present in almost all common salt and some kinds contain relatively considerable amounts of it.

Below will be given some results on salts used in packing-house products. The results are rather under than over the truth, as some of the tests were made without all the necessary refinements of the process as it now stands.



Designation of the salt.	Boric acid. Per cent.	Grains per pound avoird.
Kansas No. 2 rock salt.....	0.005000	0.35
Foreign sea salt.....	0.010900	0.76
Foreign sea salt.....	0.006448	0.45
Cheshire salt.....	0.000992	0.07
XXX Casing salt.....	0.000620	0.0435
Kansas fine salt.....	0.000620	0.0435
Kansas rock salt No. 2.....	0.001240	0.0870
Louisiana rock salt.....	0.000992	0.06944

There is not a salt here but what would give a good qualitative test by the delicate method indicated in this paper, and some of them would show up under the less refined test of the steam-bath.

THE CUDAHY PACKING CO.,  
SOUTH OMAHA, NEB.

---

[CONTRIBUTION FROM THE TEXAS EXPERIMENT STATION.]

### AVAILABILITY OF PHOSPHORIC ACID OF THE SOIL.<sup>1</sup>

By G. S. FRAPS.

Received May 4, 1906.

THE availability of the constituents of a soil depends upon several factors. The chemical compounds which are capable of being absorbed by plants and are exposed to the action of the plant roots may be termed *chemically available*. The compounds enclosed in the soil grains, or otherwise protected from soil moisture or the action of plant roots, may be called *physically unavailable*. During the growing season of the plant, chemically or physically unavailable food is converted into chemically available forms. This may be termed *weathering availability*. Further, different plants have different powers of utilizing the plant food presented to them; this may be termed a *physiological availability*. All these factors are worthy of consideration in soil problems. Chemically available plant food has been given the greatest attention, but for success in solving the problems of the soil all factors must be considered and valued.

In seeking a method for the determination of chemically available phosphoric acid, several factors again must be considered: first, the solubility of the soil phosphates in the solvent; second, the solubility of other soil constituents; third, fixation by the soil; and fourth, availability of the chemically available plant food.

<sup>1</sup> Read at the New Orleans meeting of the American Chemical Society.